

# MODEL FF-36B72 (60 & 84)

# SECONDARY FLOOR FILTER

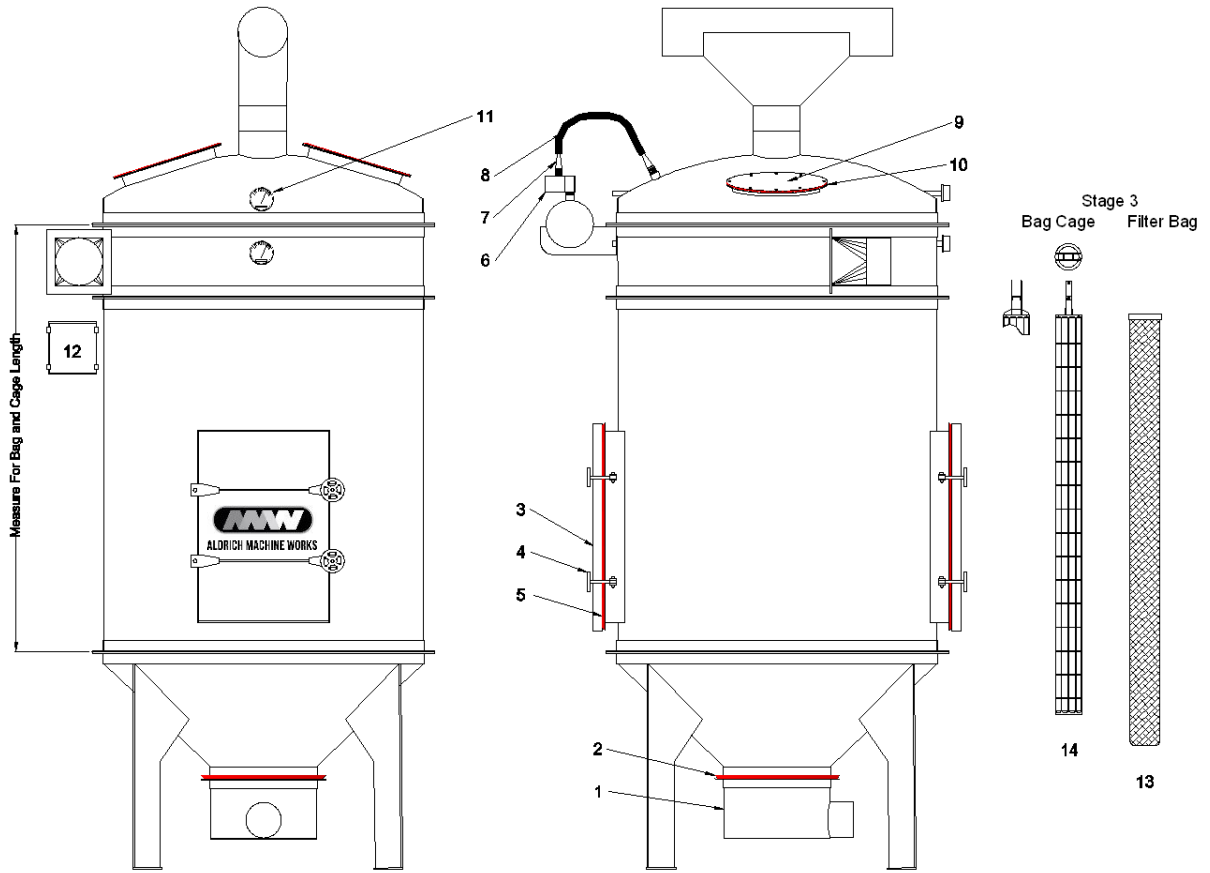

ITEM	PART DESCRIPTION	PART NUMBER	QTY.
1	Bucket with 6" Port (bolt on)	FF-100-01	1
2	Bucket Seal Gasket (a. Triangular, b. Flat Angle Ring Gasket)	FF-TRE, FFG-18-1/8	1
3	Side Door	FF-100-02	2
4	Side Door Handle 5" diameter 5/8" Thread	92311A534B	4
5	Side Door Gasket (a. Triangular, b. U-shaped)	FF-TRE, FF-923	2
6	Solenoid Valve - 1" High Pressure 110VAC	A-835.1	9
7	Barb Connector 1" - Straight or 90°	FF12-003	9
8	1" Hose - High Pressure	FF20026992	9
9	Top Access Door 18" diameter	FF-100-03	2
10	Top Access Door Gasket (Flat Angle Ring Gasket)	FFG-18-1/8	2
11	Vacuum Gauge 0-15" Hg	9749297	2
12	Stepper Board Solenoid Actuator - 110VAC	7937-2-8	1
13	Filter Bag 60" / 72" / 84"	B-557, B-569, B-581	36
14	Filter Bag Cage 60" / 72" / 84"	C-557, C-569, C-581	36